

SUNON®

Modern HVLS Fan



GENERAL

| | | |
|----------------------|-----------------|----------|
| Customer | - | |
| Model | BCNC1DA060A-01F | |
| SEQ | K1901042-0 | |
| Fan diameter | 1.5 m | 60 in. |
| Color | White | |
| Airfoil material | ABS | |
| Number of airfoils | 3 | |
| Number of fan speeds | 6 | |
| Weight | 6.3 Kg | 13.86 lb |

CONTROL UNIT



POWER & CONTROLS

| | |
|--------------|--------------------------|
| Power source | 220-240 VAC, 1Φ, 50-60Hz |
| Control | Remote Control |

MOTOR

| | | |
|-------------------------------|-------------------------|-------------|
| Motor type | BLDC Direct Drive Motor | |
| Operational temperature range | -10°C~50°C | 14°F~ 122°F |

PERFORMANCE¹

| | | |
|-----------------------------|--------------------------|------------|
| Speed (min/max) | 50 / 120 RPM | |
| Rated current (min/max) | 0.08 / 0.43 A | |
| Power consumption (min/max) | 5 / 50 W | |
| Max airflow | 18,590 m ³ /h | 10,950 CFM |
| Noise | <35 dB(A) | |

MOUNTING

| | | |
|------------------|-----------------|---------|
| Mounting options | I-Beam / Glulam | |
| Extension tube | 525mm | 1.72 ft |

RATING & CERTIFICATIONS

| | | |
|----------------|---|--|
| Environment | <input checked="" type="checkbox"/> Indoor <input type="checkbox"/> Outdoor(Rating:IP55) ² | |
| Certifications | CE | |

DIMENSIONS

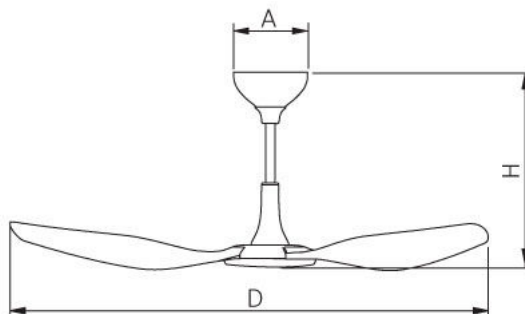

| | | |
|---|--------|--------|
| D | 1.5 m | 60 in. |
| A | 200 mm | 0.66ft |
| H | 525 mm | 1.72ft |

Note 1.Performance in field condition may vary due to environment conditions.

Note 2.Not suitable for salt air environment.